

## Model KBW 240 | Growth chambers with light

The BINDER climate chamber with illumination of the KBW series achieves homogeneous light distribution with its natural illumination. That allows this growth chamber to create constant lighting and temperature conditions.

### BENEFITS

- Patented lighting system ensures homogeneous light distribution
- Flexible positioning of illumination cassettes, three different light spectra, individually selectable
- Integrated weekly program in real-time

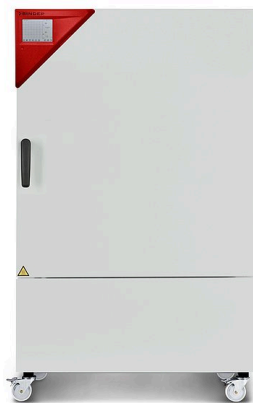

Model 240

### MAIN FEATURES

- Temperature range: 0 °C to 70 °C
- Temperature range with light: 5 °C to 60 °C
- positionable illumination cassettes, each with 5 fluorescent tubes
- APT.line™ preheating chamber technology
- Adjustable fan speed
- Intuitive touchscreen controller with time-segment and real-time programming
- Internal data logger, measured values can be read out in open format via USB
- Unit self-test for comprehensive status analysis
- Tight-sealing inner door made of safety glass (ESG)
- Avoidance of glass corrosion by special TIMELESS coating
- stainless steel racks
- Access port with silicone plug, 30 mm, left
- Class 3.1 independent temperature safety device (DIN 12880) with visual and audible temperature alarm
- Computer interface: Ethernet
- Door heating

### ORDERING INFORMATION

Interior volume [cu.ft.]	Voltage	Option model	Version	Art.-No.
8.7	200...240 V 1~ 50 Hz	Standard	KBW240-230V	9020-0338

**TECHNICAL DATA**

Description	KBW240-230V <sup>1</sup>
<b>Article Number</b>	<b>9020-0338</b>
<b>Performance Data Temperature</b>	
Temperature range with 100% illumination [°C]	5...60
Temperature range without illumination cassettes [°C]	0...70
Temperature variation with 100% illumination [± K]	0.5
Temperature variation without illumination cassettes [± K]	0.5
Temperature fluctuation with 100% illumination [± K]	0.2
Temperature fluctuation without illumination cassettes [± K]	0.1
<b>Lightdata per Illumination Cassettes</b>	
Daylight tubes [W/m <sup>2</sup> ]* <sup>2</sup>	24
Daylight tubes [lx]* <sup>2</sup>	9000
Fluora® growth lamps [W/m <sup>2</sup> ]* <sup>2</sup>	23
Fluora® growth lamps [lx]* <sup>2</sup>	7500
Arabidopsis lamps [W/m <sup>2</sup> ]* <sup>2</sup>	32
Arabidopsis lamps [lx]* <sup>2</sup>	11000
<b>Electrical data</b>	
Rated Voltage [V]	200...240
Power frequency [Hz]	50
Nominal power [kW]	1.4
Unit fuse [A]	16
Phase (Nominal voltage)	1~
<b>Measures</b>	
Interior volume [cu.ft.]	8.7
Net weight of the unit (empty) [lbs]	445
Permitted load [lbs]	220
Load per rack [lbs]	66
Wall clearance back [in]	3.94
Wall clearance sidewise [in]	3.94
<b>Internal Dimensions</b>	
Width [in]	25.61
Height [in]	30.93
Depth [in]	19.11
<b>Doors</b>	
Inner doors	1
Unit doors	1
<b>Housing dimensions not incl. fittings and connections</b>	
Width net [in]	36.45
Height net [in]	57.7
Depth net [in]	31.52
<b>Environment-specific data</b>	
Energy consumption at 37 °C and with illumination [Wh/h]	450
Sound-pressure level [dB(A)]	53
<b>Fixtures</b>	
Number of shelves (std./max.)	2/7
Number of illumination cassettes (std./max.)	2/2

- 1 All technical data is specified for unloaded units with standard equipment at an ambient temperature of +22 °C ±3 °C and a power supply voltage fluctuation of ±10 %. The temperature data is determined in accordance to BINDER factory standard following DIN 12880, observing the recommended wall clearances of 10 % of the height, width, and depth of the inner chamber. Technical data refers to 100 % fan speed. All indications are average values, typical for units produced in series. We reserve the right to change technical specifications at any time.
- 2 Average value, measured at 25 °C with a spherical sensor (±10 %) by 12 cm below the light cassette. The values given in W/m<sup>2</sup> refer to global radiation.

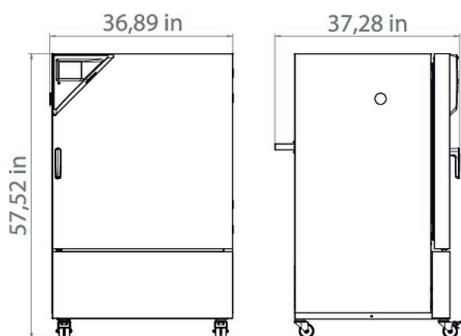
**DIMENSIONS INCL. FITTINGS AND CONNECTIONS [MM]****OPTIONS**

Designation	Description	*	Art.-No.
<b>Calibration certificate, temperature</b>	temperature measurement incl. certificate and 27 measuring points at specified temperature	-	8012-1599
	additional flexible Pt 100, interior, for displaying the temperature on the unit display	-	8012-1746
	Additional serial interface can be used parallel to Ethernet, for Multi Management Software APT-COM™	-	8012-1742
	for controlling 3 relay contacts via program regulators, accessible via 6-pin DIN socket (max. 24 V - 2.5 A)	-	8012-0679
	for temperature ( $\pm 2$ °C) and humidity ( $\pm 5$ % RH), accessible via 6-pin DIN socket (max. 24 V - 2.5 A), with audible signal that can be switched off	-	8012-1757
	for temperature and humidity values (output not adjustable)	-	8012-1721
	for temperature; for extending the measurement in center of chamber to include another test temperature	-	8012-1121
	Illumination cassettes equipped with Arabidopsis fluorescent tubes instead of daylight fluorescent tubes	-	8012-0655
	Illumination cassettes equipped with FLUORA® fluorescent tubes instead of daylight fluorescent tubes	-	8012-0654
	including certificate, illumination and irradiance for visible light and UV-A, 25 measuring points on 3 measurement levels, as well as spectral distribution (250 – 785 nm)	-	8012-0910
<b>Options/Accessories</b>	left		
	30 mm	01	8012-1445
	50 mm	01	8012-1475
	lockable door handle	-	8012-1775
	Measurement in center of chamber at specified temperature	-	8012-1140
	positioned at bottom level, max. load 45 kg, with additional attachment for operation of shaking device, stirring device or roller bottle system	-	8012-1429
	right		
	30 mm	01	8012-1439
	50 mm	01	8012-1469
	temperature measurement incl. certificate, 15- 18 measuring points at specified temperature	-	8012-1578
	temperature measurement incl. certificate, 9 measuring points at specified temperature	-	8012-1557
	top		
	30 mm	01	8012-1451
	50 mm	01	8012-1457
	100 mm	01	8012-1463
Waterproof, switched flush-mounting box (CA3GD) for nominal voltage in unit interior, with cover and corresponding plug (nominal voltage; max. 500 W; max. 90 °C; protection class IP67)	07	8012-1741	
with visual alarm (DIN 12880)	-	8012-1750	

\* Notes › See last page

## ACCESSORIES

Designation	Description	*	Art.-No.
<b>Multi Management Software</b>	Multi Management Software APT-COM™ version 4, BASIC edition	19	9053-0039
	version 4, GLP edition	19	9053-0042
	version 4, PROFESSIONAL edition	19	9053-0040
<b>Options/Accessories</b>	Stainless steel	–	6004-0040
	stainless steel	–	6004-0101
	concentrated, for gentle remove of residual contaminants; 1 kg	–	1002-0016
	fasteners (1 set of 4) for additional security of racks	–	8012-0620
	IQ/OQ documents – supporting documents for validation performed by customers, consisting of: IQ/OQ checklists incl. calibration guide and comprehensive unit documentation; parameters: temperature, humidity, and light values		
	Digital in PDF format	–	7057-0003
	Hard copy inside folder	–	7007-0003
	IQ/OQ/PQ documents – supporting documents for validation performed by customers, according to customer requirements, PQ section added to qualification folder IQ/OQ; parameters: temperature, humidity, and light values		
	Digital in PDF format	–	7057-0007
	Hard copy inside folder	–	7007-0007
	LOG ANALYZE software kit, configuration and evaluation software for all BINDER Data Logger Kits (incl. USB data cable)	19	8012-0821
	RS 422 cable set and RS 485 / RS 422 interface converter for connection to 10-way plug distributor		
	115 V option model	–	8012-0599
230 V option model	–	8012-0589	
stainless steel, with fasteners (1 set of 4)	–	8012-0638	
T 220: For continuous temperature logging from -90 °C to 220 °C. The kit includes 1 data logger, Pt 100 sensor with 2 m extension cable and 1 magnetic fixture for mounting to the BINDER unit	19	8012-0715	

\* Notes › See last page

## SERVICES

Designation	Description	*	Art.-No.
<b>Installation services</b>			
Services	Unit function instructions for operation and programming of the controller	18	DL10-0700
	Unpacking and setting up of unit, connecting to existing connections, and checking function	13, 18	DL10-0300
<b>Preventive maintenance</b>			
Services	Executive of equipment inspection according to maintenance plan	14, 18	DL20-0400
<b>Calibration services</b>			
Services	Expansion – including certificate, each additional measuring point in center of chamber at specified test temperature	14, 16, 17, 18	DL30-0102
	Radiometric measurement in the visible spectrum with determination and documentation of intensity distribution from an illumination cassette on 3 measurement levels, including certificate	14, 16, 17, 18	DL31-0000
	Temperature calibration with 1 measuring point in center of chamber at a specified test temperature, including certificate	14, 16, 17, 18	DL30-0101
	Temperature measurement with 27 measuring points at a specified test temperature, including certificate	14, 16, 17, 18	DL30-0127
	Temperature measurement with 9 measuring points at a specified test temperature, including certificate	14, 16, 17, 18	DL30-0109
<b>Validation services</b>			
Services	Execution of IQ/OQ including light photometry in accordance with qualification folder	15, 18	DL43-0400
	Execution of IQ/OQ/PQ in accordance with qualification folder	15, 18	DL44-0500
<b>Warranty service</b>			
Services	The warranty is extended from 2 to 3 years from the delivery date, wear parts are excluded	–	DL02-2041
	The warranty is extended from 2 to 5 years from the delivery date, wear parts are excluded	–	DL02-2042

\* Notes › See last page

**NOTES**

- 01 Condensation may occur in the area around the access port. Access ports may be placed in custom locations for an additional charge.
- 02 UL mark is not granted when this option is used.
- 03 Heat resistant only to max. 200 °C.
- 04 Only available on units rated for 230 V.
- 07 The additional heat input may affect the temperature behavior.
- 09 Not in conjunction with the optional access port, door with window and interior lighting.
- 10 Not available on 23-liter units.
- 11 Not available on 23- or 53-liter units.
- 12 Only available on units rated for 230 V or 400 V.
- 13 Installation and connections take place at unit location; transport within the company only upon consultation.
- 14 We recommend a BINDER service contract to cover unit inspections, calibrations and validations.
- 15 OQ according to Yellow Paper = completed factory validation documentation of all OQ checklists.
- 16 Sensor calibration is performed in an accredited calibration laboratory.
- 17 Calibration is performed according to the BINDER factory standard.
- 18 Quoted prices do not include travel costs. Please refer to the chapter on BINDER Service for travel costs for your region. Quoted prices for services performed in Switzerland do not include a country-specific added fee (available on request).
- 19 For additional accessories, refer to the Process documentation chapter.

**BINDER GmbH**

Tuttlingen, Germany  
TEL +49 7462 2005 0  
FAX +49 7462 2005 100  
info@binder-world.com  
www.binder-world.com

**BINDER Asia Pacific (Hong Kong) Ltd.**

Kowloon, Hong Kong, P.R. China  
TEL +852 39070500  
FAX +852 39070507  
asia@binder-world.com  
www.binder-world.com

**Representative Office for CIS**

Moscow, Russia  
TEL +7 495 988 15 16  
FAX +7 495 988 15 17  
russia@binder-world.com  
www.binder-world.com

**BINDER Environmental Testing  
Equipment (Shanghai) Co., Ltd.**

Shanghai, P.R. China  
TEL +86 21 685 808 25  
FAX +86 21 685 808 29  
china@binder-world.com  
www.binder-world.com

**BINDER Inc.**

Bohemia, NY, USA  
TEL +1 631 224 4340  
FAX +1 631 224 4354  
usa@binder-world.com  
www.binder-world.us